

# Device Modeling Report

COMPONENTS : CMOS DIGITAL INTEGRATED CIRCUIT  
PART NUMBER : TC74VHCT240AFT  
MANUFACTURER : TOSHIBA



**Bee Technologies Inc.**

# Truth Table

## Circuit simulation result

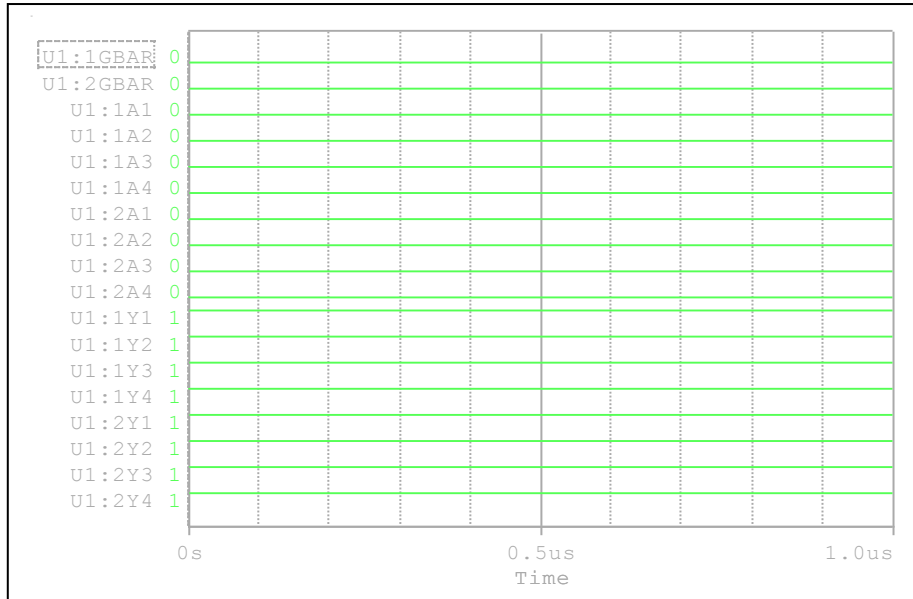

## Evaluation circuit

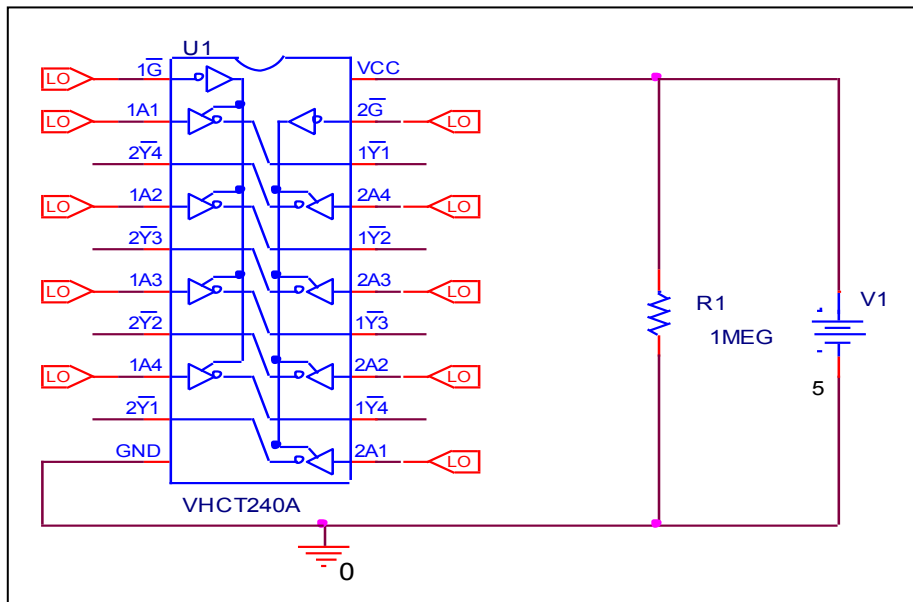

## Comparison table

Input		Output		%Error
$\bar{G}$	An	$\bar{Y}_n$ (Measurement)	$\bar{Y}_n$ (Simulation)	
L	L	H	H	0

# Truth Table

## Circuit simulation result

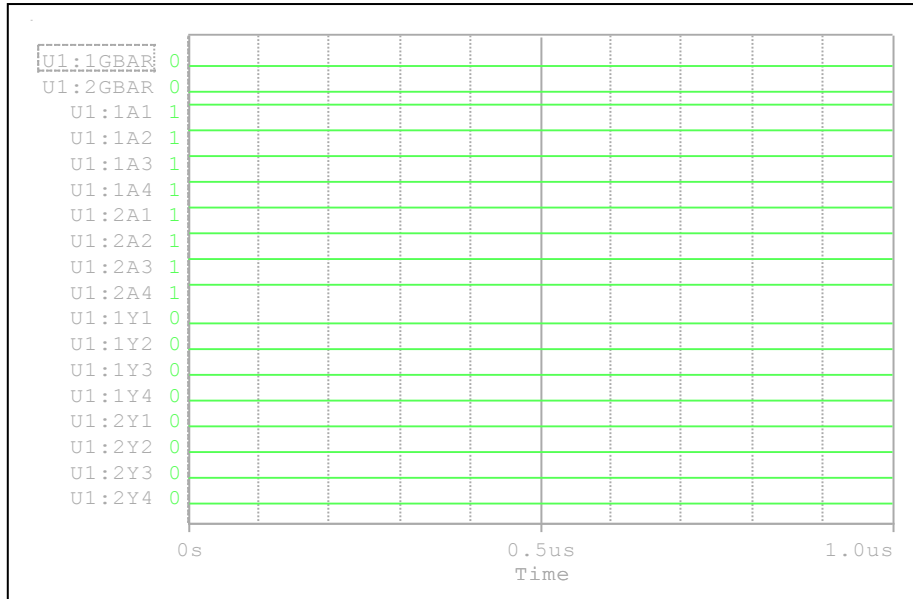

## Evaluation circuit

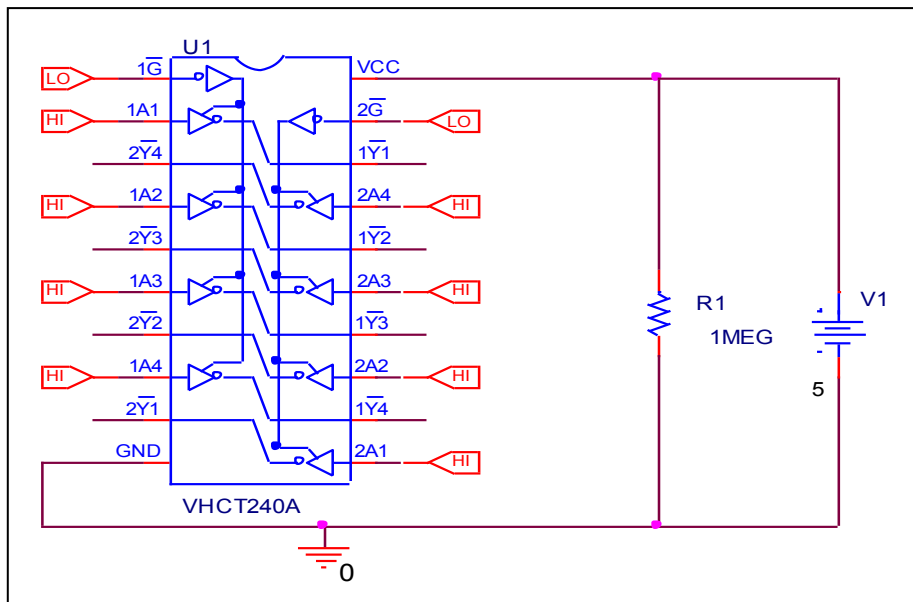

## Comparison table

Input		Output		%Error
$\bar{G}$	$A_n$	$\bar{Y}_n$ (Measurement)	$\bar{Y}_n$ (Simulation)	
L	H	L	L	0

# Truth Table

## Circuit simulation result

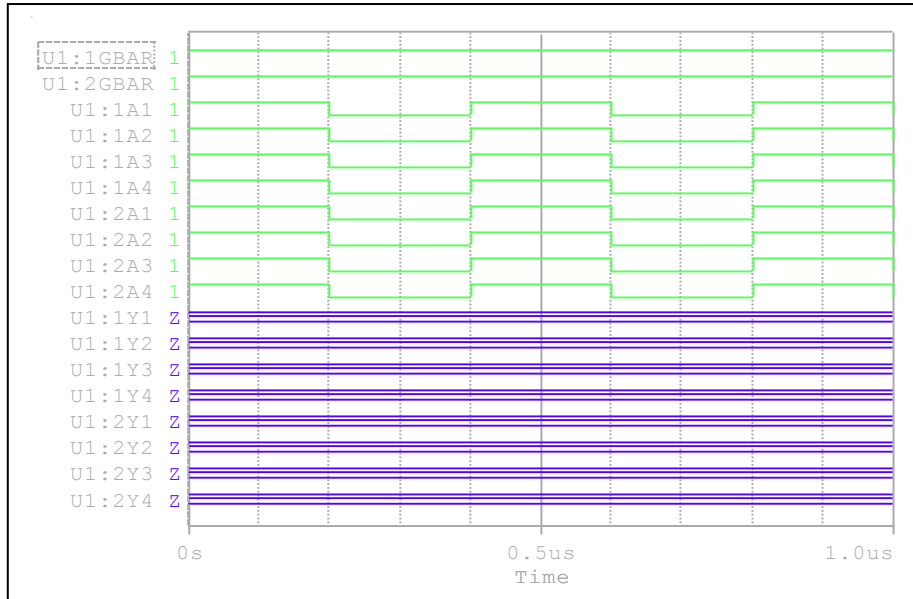

## Evaluation circuit

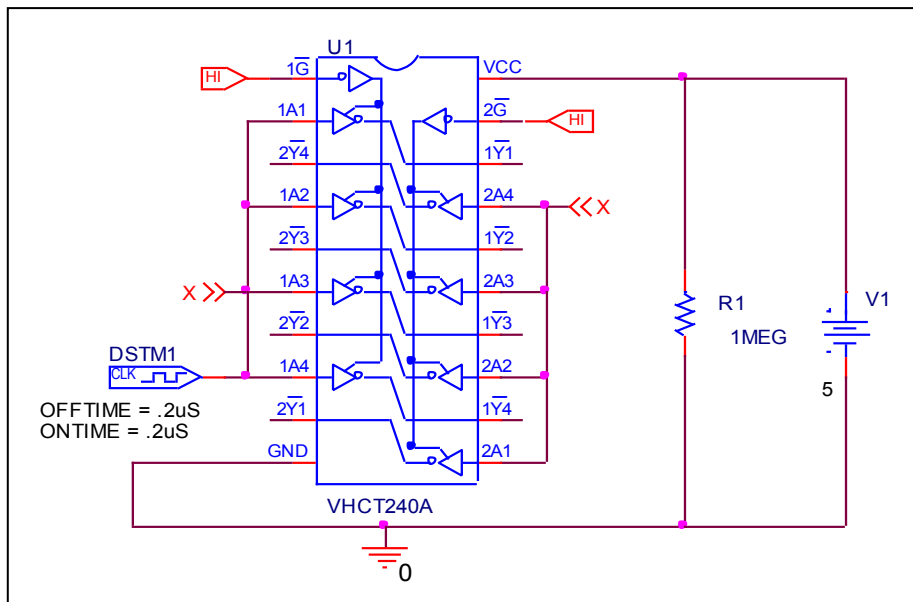

## Comparison table

Input		Output		%Error
$\bar{G}$	$A_n$	$\bar{Y}_n$ (Measurement)	$\bar{Y}_n$ (Simulation)	
H	X	Z	Z	0

# High Level and Low Level Input Voltage

## Circuit simulation result

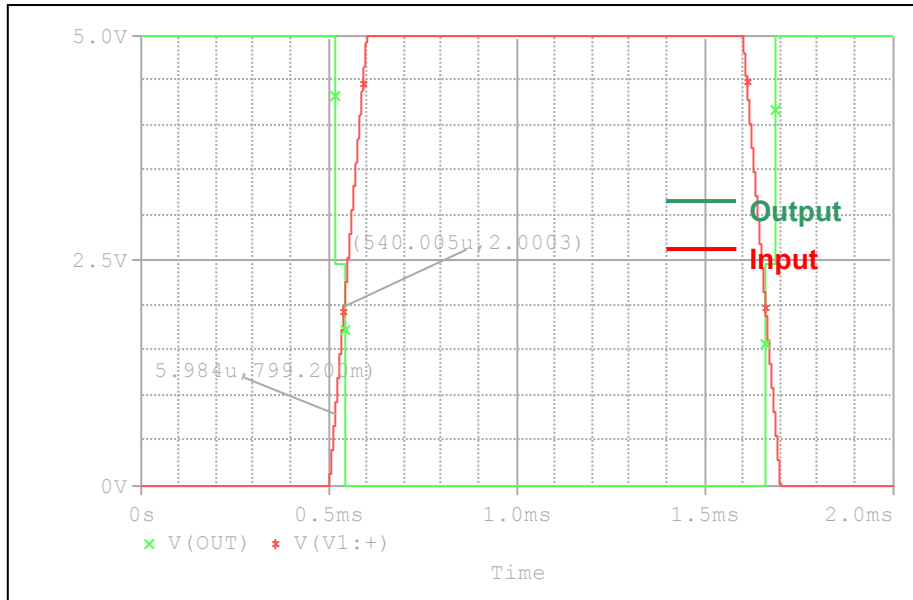

## Evaluation circuit

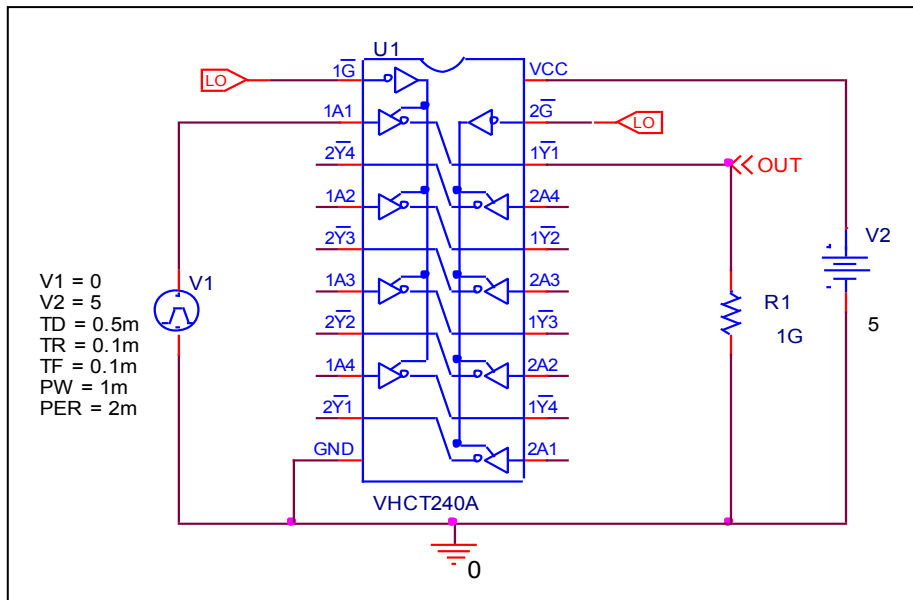

## Comparison table

$V_{CC} = 5V$	Measurement	Simulation	%Error
$V_{IH} (V)$	2	2.0003	0.015
$V_{IL} (V)$	0.8	0.7992	-0.100

# High Level and Low Level Output Voltage

## Circuit simulation result

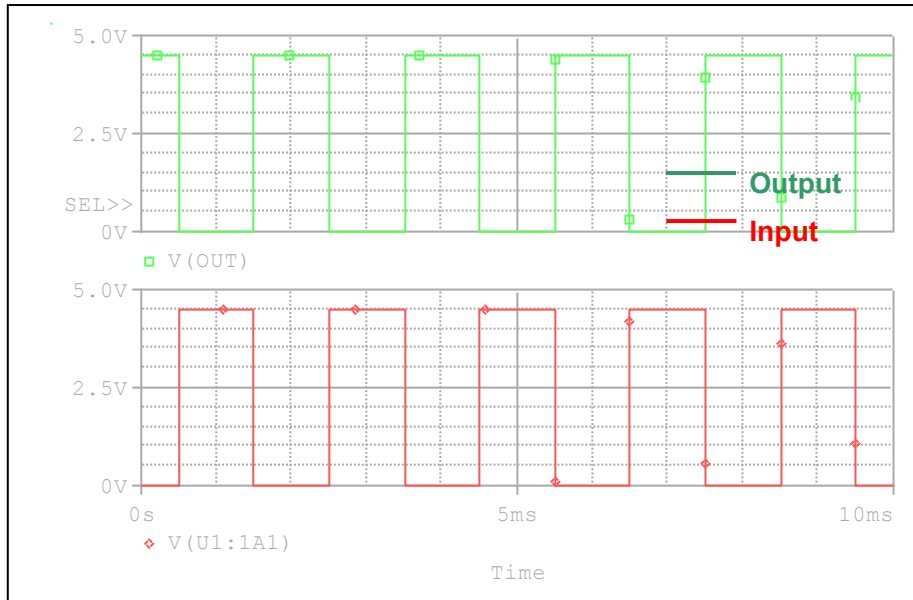

## Evaluation circuit

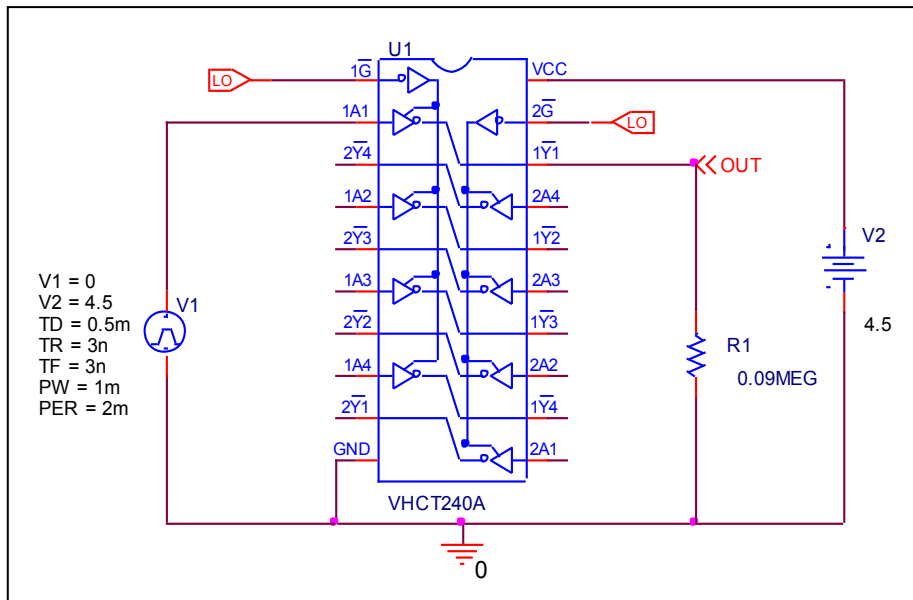

## Comparison table

$V_{CC} = 4.5V$	Measurement	Simulation	%Error
$V_{OH} (V)$	4.5	4.4986	-0.031
$V_{OL} (V)$	0	0	0

# Propagation Delay Time

## Circuit simulation result

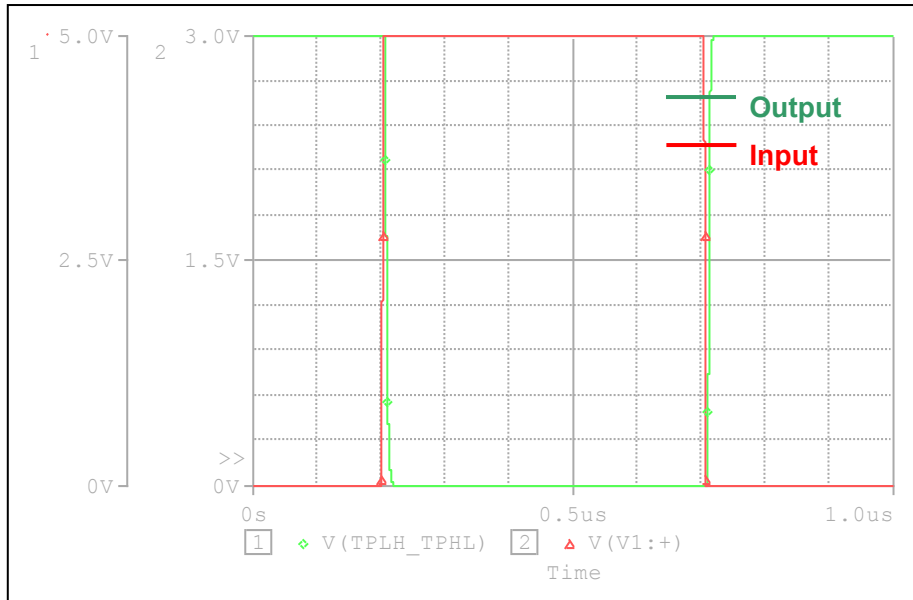

## Evaluation circuit

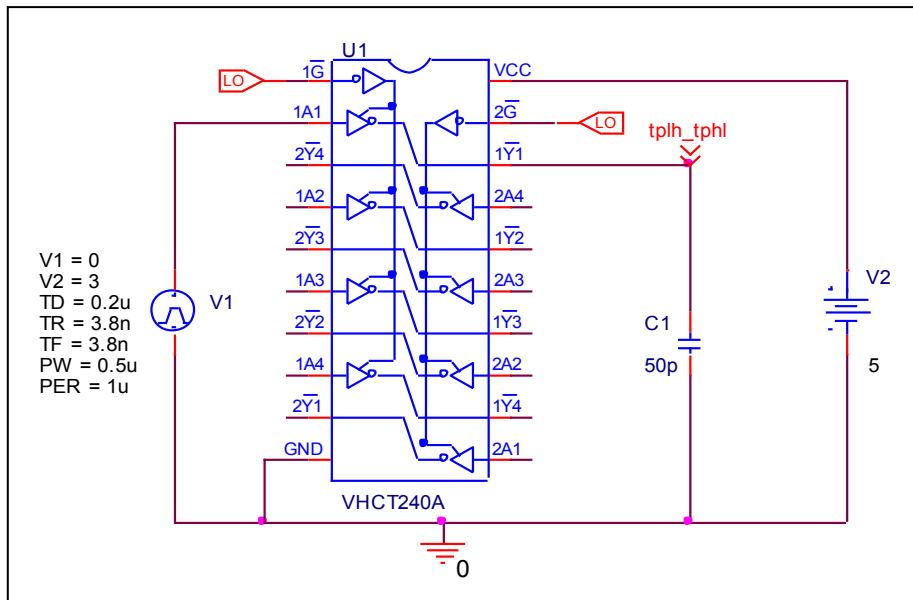

## Comparison table $C_L = 50 \text{ pF}$

$t_r = t_f = 3 \text{ ns}$	Measurement	Simulation	%Error
$t_{PLH} \text{ (ns)}$	6.1	6.1741	1.215
$t_{PHL} \text{ (ns)}$	6.1	6.1436	0.715

**Output enable time, high impedance (off) to high output ( $t_{PZH}$ )**  
**Output disable time, high to high impedance (off) output ( $t_{PHZ}$ )**

**Circuit simulation result**

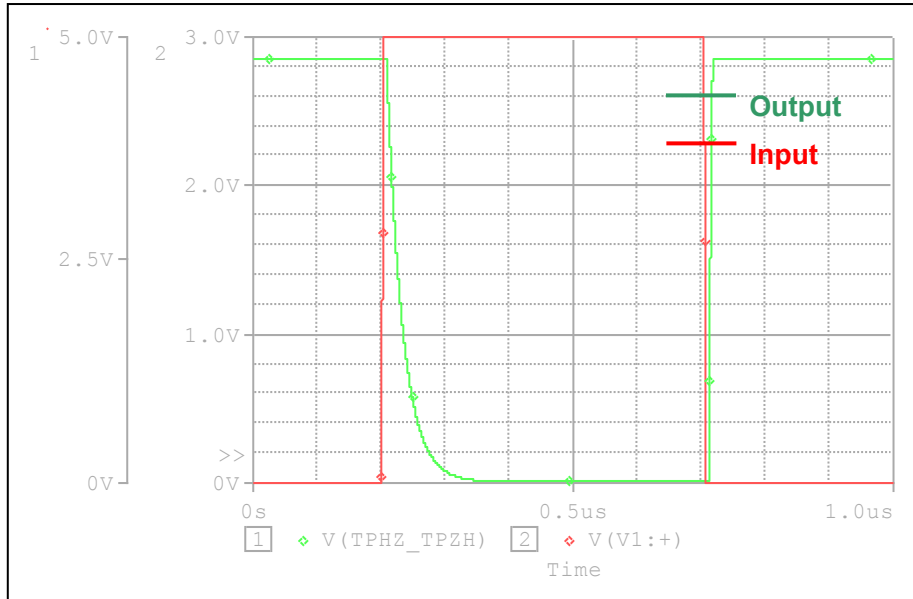

**Evaluation circuit**

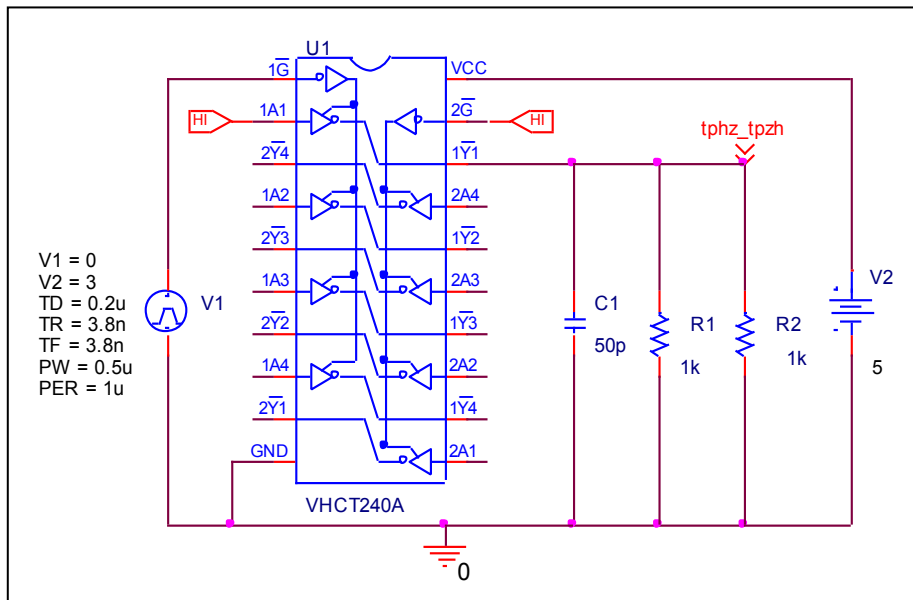

**Comparison table**  $C_L = 50 \text{ pF}$ ,  $R_L = 1 \text{ K}\Omega$

$t_r = t_f = 3 \text{ ns}$	Measurement	Simulation	%Error
$t_{PZH} \text{ (ns)}$	8.2	8.2419	0.511
$t_{PHZ} \text{ (ns)}$	8.8	8.9224	1.391



**Output enable time, high impedance (off) to low output ( $t_{PZL}$ )**  
**Output disable time, low to high impedance (off) output ( $t_{PLZ}$ )**

**Circuit simulation result**

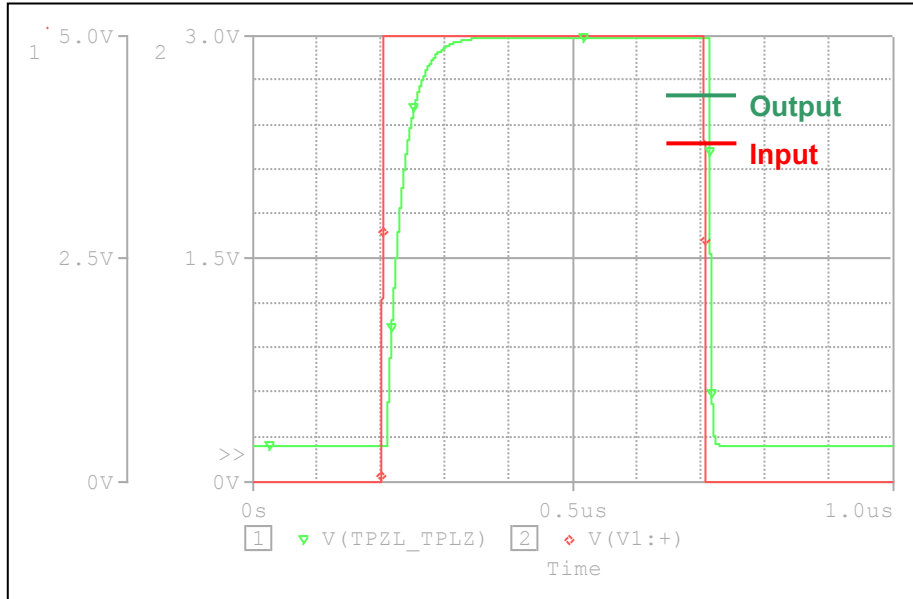

**Evaluation circuit**

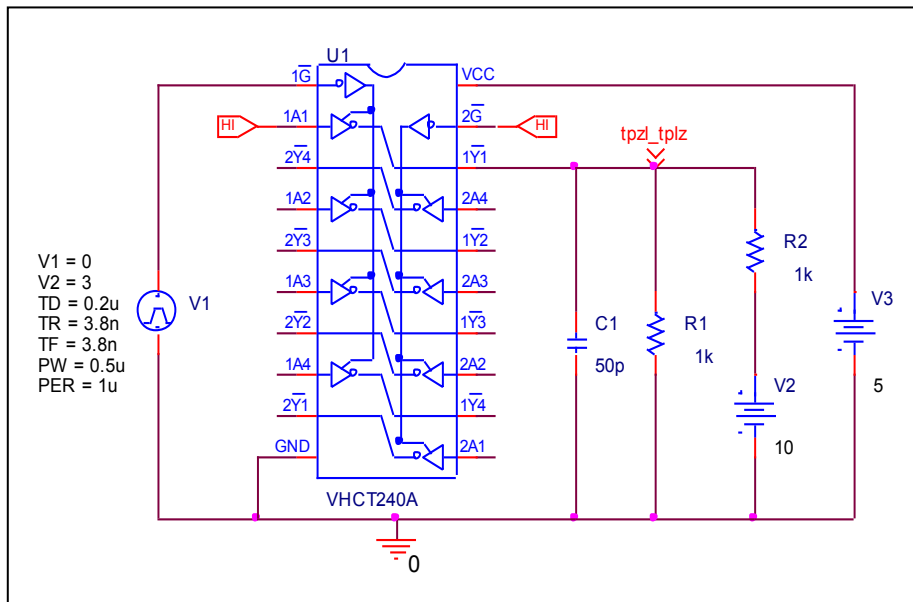

**Comparison table**  $C_L = 50 \text{ pF}$ ,  $R_L = 1 \text{ K}\Omega$

$t_r = t_f = 3 \text{ ns}$	Measurement	Simulation	%Error
$t_{PZL} \text{ (ns)}$	8.2	8.2238	0.290
$t_{PLZ} \text{ (ns)}$	8.8	8.8277	0.315